

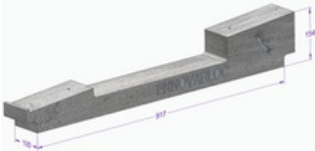







FICHA TÉCNICA

VELA 10°

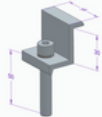
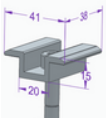
| PIEZA | NOMBRE | MATERIAL | PESO |
|---|-------------------------------------|---------------------------------|------------|
|  | EnnovaBloc 10° | Hormigón | 28 / 37 Kg |
|  | EnnovaBloc 10° B | Hormigón | 36.5 Kg |
|  | EnnovaBloc 10° C | Hormigón | 47.5 Kg |
|  | EnnovaBloc 10° D | Hormigón | 62.5 Kg |
|  | EnnovaBloc 10° E | Hormigón | 73.4 Kg |
|  | Unión Terminal | Aluminio | 0.024 Kg |
|  | Unión Intermedia | Aluminio | 0.020 Kg |
|  | Espuma Protectora 1100 x 150 x 3 | Espuma de Polietileno Rugosa | 0.020 Kg |

IMPORTANTE: Máximo par de apriete, 100 Newtons Metro (NM)



FICHA TÉCNICA VELA 10°

PERFIL MEDIO

| PIEZA | NOMBRE | MATERIAL | PESO |
|---|-------------------------------------|---------------------------------|------------|
|  | EnnovaBloc 10° | Hormigón | 28 / 37 Kg |
|  | EnnovaBloc 10° B | Hormigón | 36.5 Kg |
|  | EnnovaBloc 10° C | Hormigón | 47.5 Kg |
|  | EnnovaBloc 10° D | Hormigón | 62.5 Kg |
|  | EnnovaBloc 10° E | Hormigón | 73.4 Kg |
|  | Perfil 50 x 26 x 1000 | Aluminio | 0.625 Kg |
|  | Perfil en U 32 x 48 x 70 | Aluminio | 0.047 Kg |
|  | Unión Terminal | Aluminio | 0.048 Kg |
|  | Unión Intermedia | Aluminio | 0.049 Kg |
|  | Espuma Protectora 1100 x 150 x 3 | Espuma de Polietileno Rugosa | 0.020 Kg |

IMPORTANTE: Máximo par de apriete, 100 Newtons Metro (NM)

ENNOVABLOC 10° A

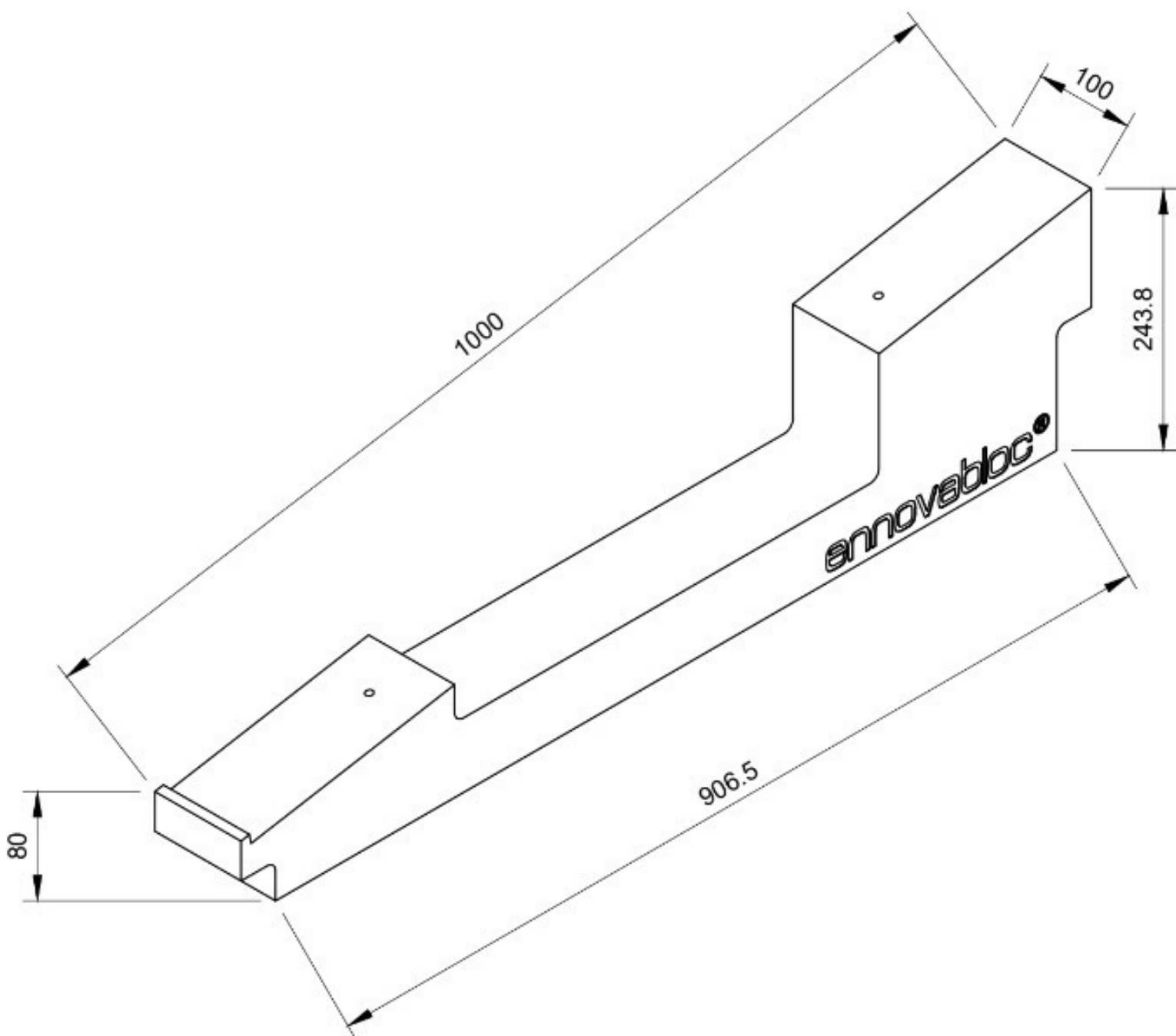

| PESO | MATERIAL | ESCALA |
|-------|----------|--------|
| 28 Kg | HORMIGÓN | 1:6 |

ENNOVABLOC 10° B



ennova
tu propia energía

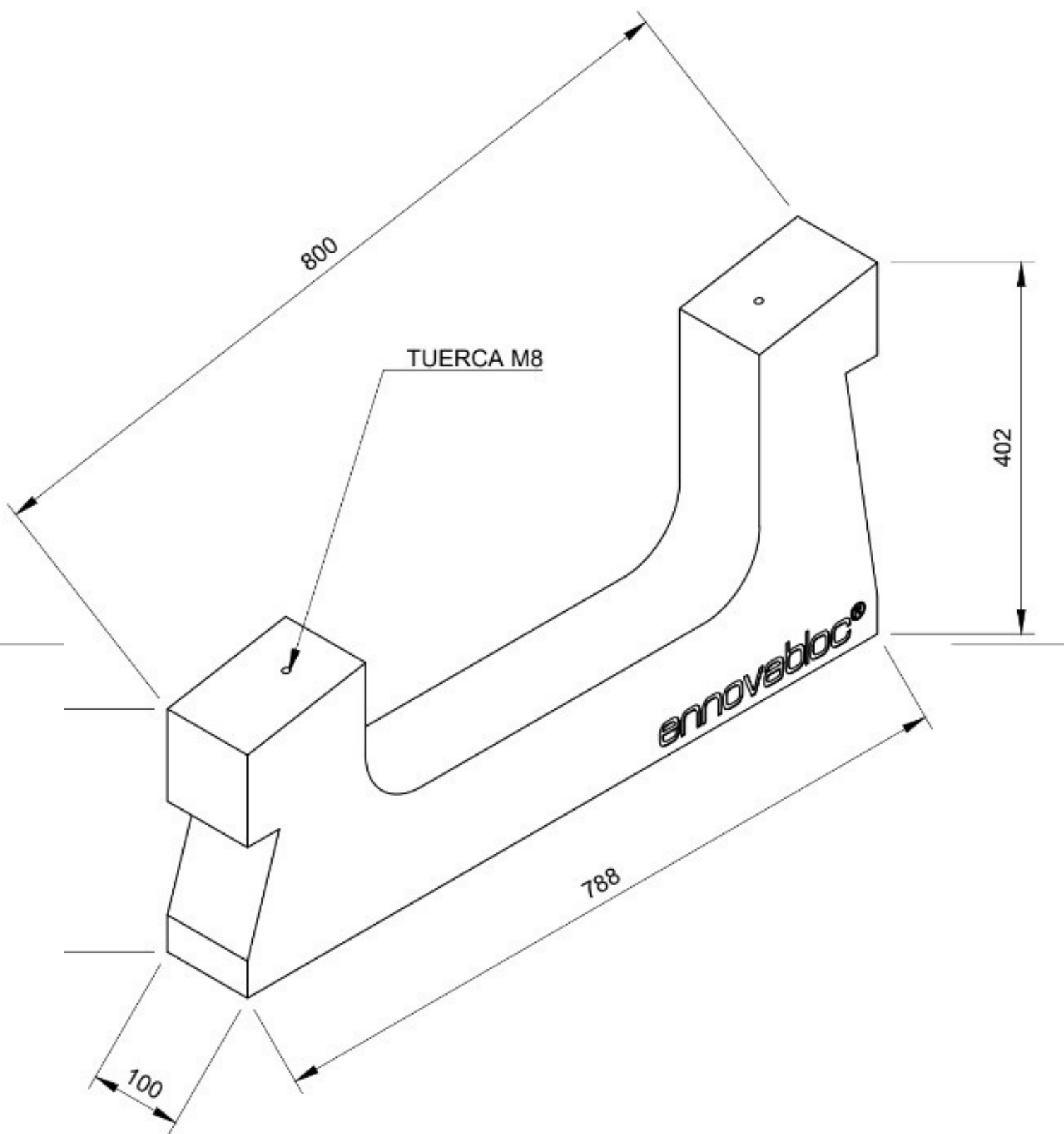

| PESO | MATERIAL | ESCALA |
|---------|----------|--------|
| 36.5 Kg | HORMIGÓN | 1:6 |

ENNOVABLOC 10° C



ennova
tu propia energía

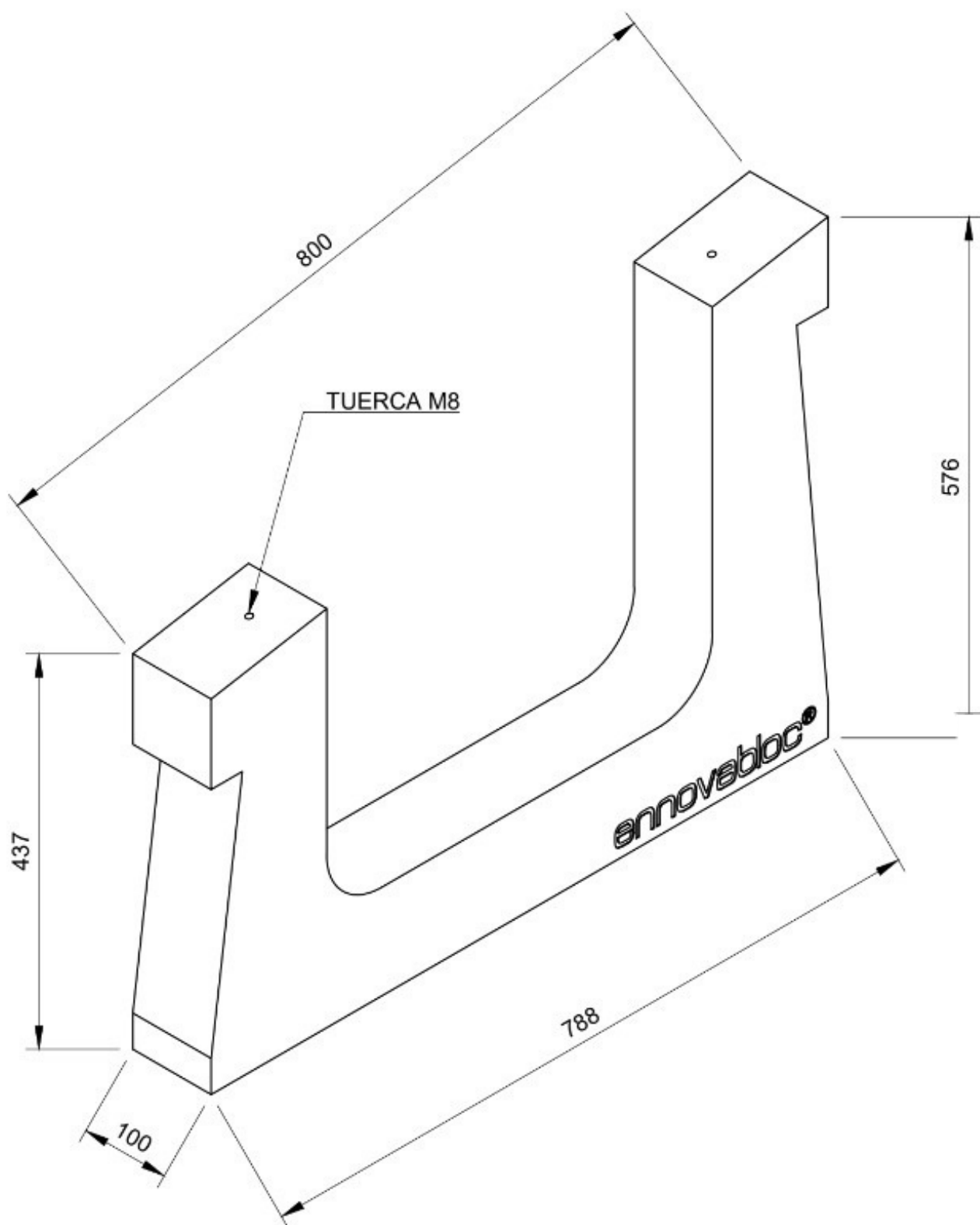

| PESO | MATERIAL | ESCALA |
|---------|----------|--------|
| 47.5 Kg | HORMIGÓN | 1:6 |

ENNOVABLOC 10° D



ennova
tu propia energía

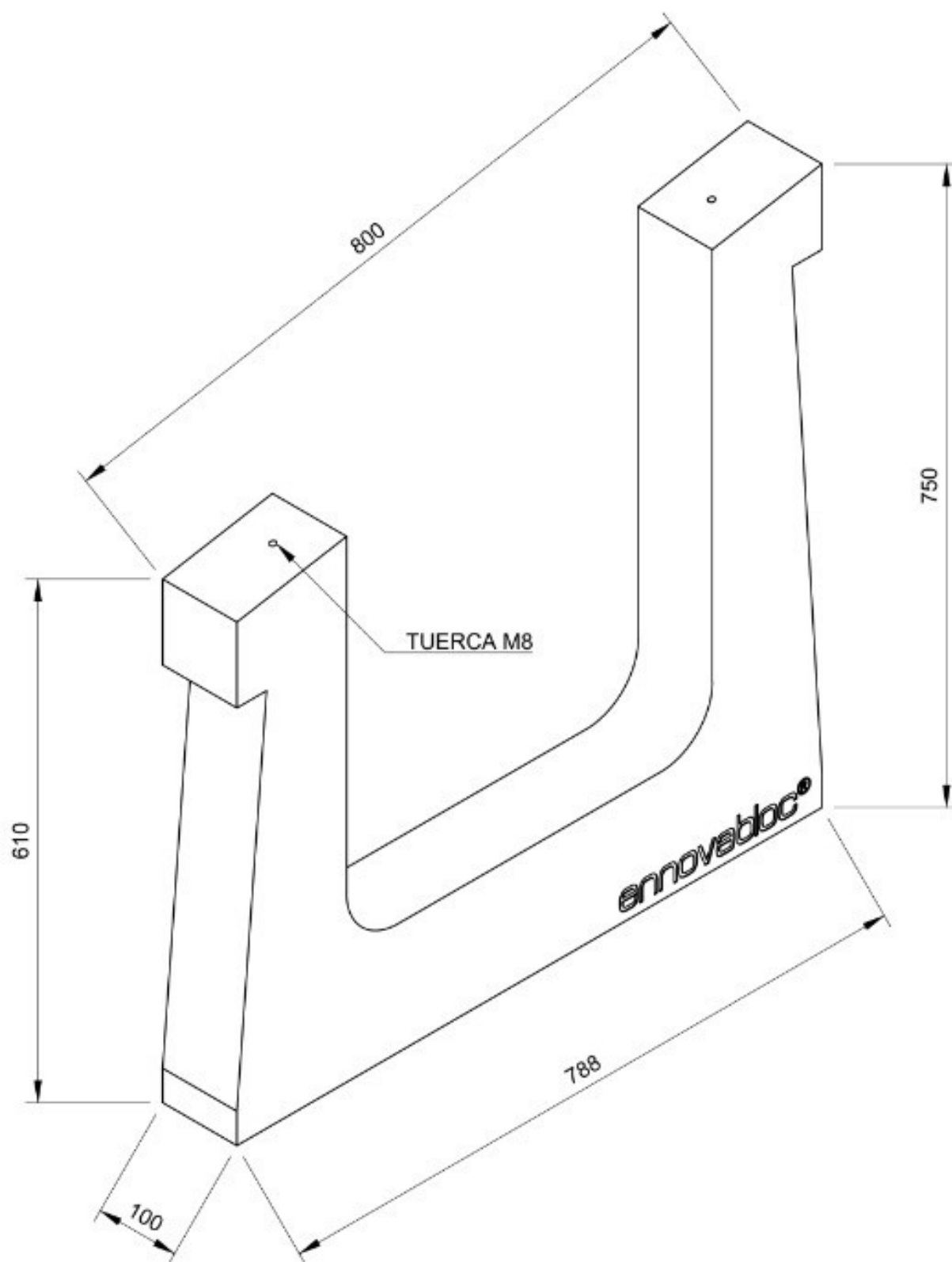

| PESO | MATERIAL | ESCALA |
|---------|----------|--------|
| 62.5 Kg | HORMIGÓN | 1:6 |

ENNOVABLOC 10° E



ennova
tu propia energía

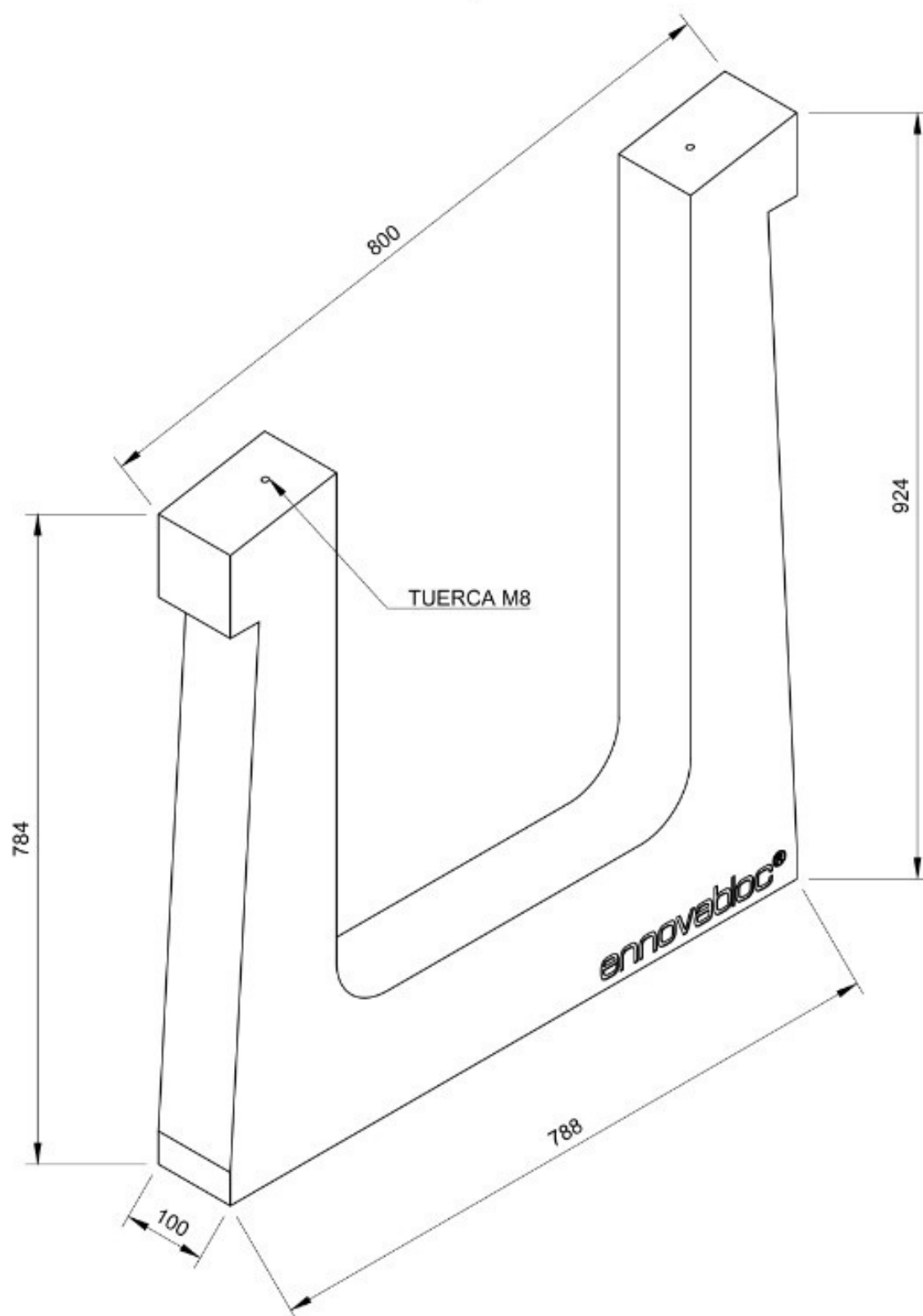

| PESO | MATERIAL | ESCALA |
|---------|----------|--------|
| 73.4 Kg | HORMIGÓN | 1:6 |